

ROADWAY WIDENING DETAIL

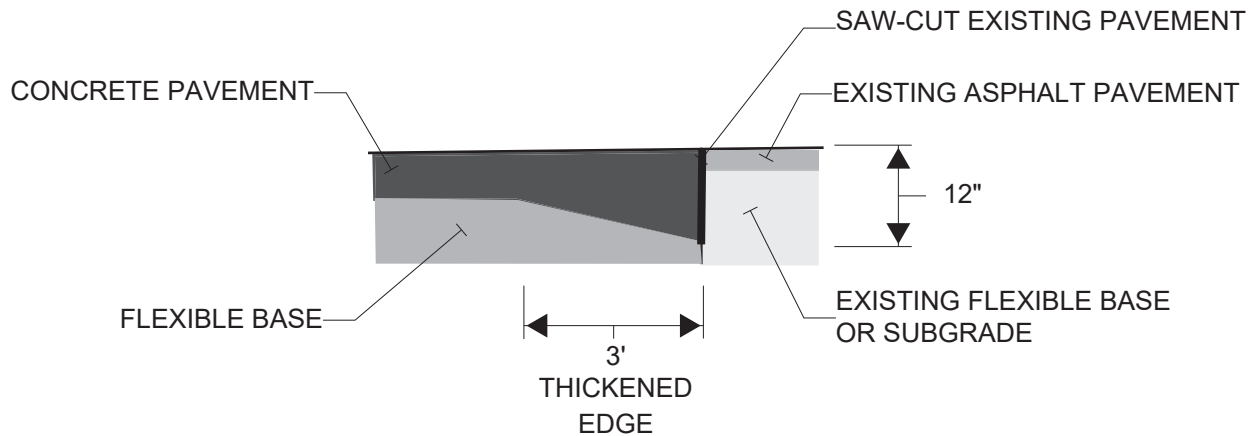

CONCRETE TO ASPHALT PAVEMENT JUNCTION DETAIL

CONCRETE/ASPHALT PAVEMENT JUNCTION DETAIL NOTES

1. CONCRETE PAVEMENT SHALL BE JOINTED REINFORCED CONCRETE PAVEMENT (JRCP) ONLY.



MISCELLANEOUS DETAILS

GUADALUPE COUNTY STANDARD DETAILS

SCALE:	N.T.S.	DATE:	6/26/2023
DSGN. BY:	ENG.	DRAWN BY:	JRS
		SHEET NO.:	1